

Strip 4 Dual

Coating Plate

The new generation of PES Foil based coating plates suitable for use with both water based and UV coatings.

Bi-directional and easily strippable, the Strip 4 Dual's polyester foil also makes it ideal for archiving and re-use.

COLOUR - STRIP 4 DUAL

Standard Thickness

Dark Grey

1,15 +/- 0,02 mm

1,35 +/- 0,02 mm

1,95 +/- 0,02 mm

2,15 +/- 0,02 mm

2,35 +/- 0,02 mm

BASE

STENCIL DEPTH OF

Strip 4 dual - 1,15 mm

Strip 4 dual - 1,35 / 1,95 mm

Strip 4 dual - 2,15 / 2,35 mm

Polyester

0,80 mm

1,00 mm

1,00 mm

Ground & Polished

0% @ 500 N/5 cm

SURFACE FINISH

ELONGATION

SUITABLE FOR ARCHIVING & RE-USE

Yes

Bi-Directional

Yes

APPLICATION

- Sheetfed
- Heatset
- Coldset
- Packaging
- Coating
- Metal

VARNISH STRIP 4 DUAL

- UV
- Aqueous

● Recommended ● Suitable ● Not recommended

STRUCTURE

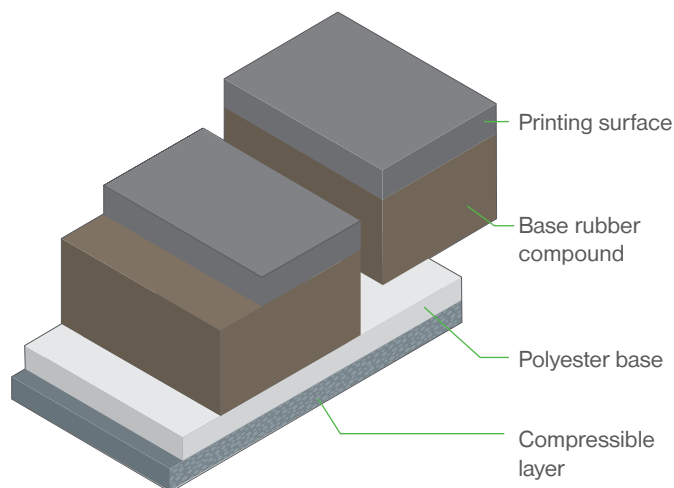
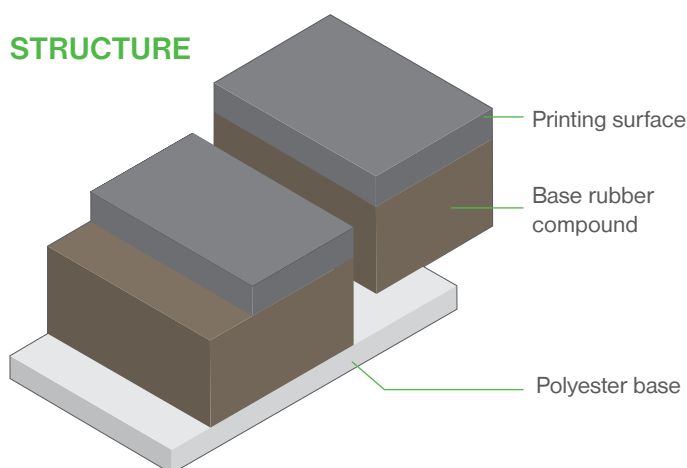

CHARACTERISTICS

Micro-ground Coating Surface

ADVANTAGES

The specially formulated surface compound ensures optimal coating transfer with minimum pressure settings. High resistance to a wide variety of washes and press room chemicals ensures a long life time.

Easy to Peel Coating Layer

A high stencil depth is achieved by the complete removal of the top compound from the cut resistant PES ply. Easy and clean stencil cutting either by hand or with the use of a CAD plotter. For optimal surface stripping always cut down to the PES foil.